

PRIMEWORLD LIMITED

TXS12 RANGE OF TOROIDAL CURRENT SENSE AND GATE DRIVE TRANSFORMERS



TECHNICAL DESCRIPTION:

Primeworld TXS12 range of current sense and gate drive transformers is manufactured in one mechanical outline (A), providing a low cost solution for current sense and Power MOSFET gate drive applications.

Windings are enamelled copper wire, or “TEX-E” (Furukawa) triple insulated wire for applications requiring reinforced insulation, wound on a 13mm diameter, low loss high frequency ferrite toroidal core. Wound core is secured on to the flame retardant glass reinforced PET base with polyurethane glue, and windings are terminated using SnAgCu solder.

The TXS12 range is designed for use in switch mode power supplies, dc/dc converters and inverters.

RATINGS AND CHARACTERISTICS:

Maximum Working Voltage: 275V ac rms., 500V dc

Insulation Test Voltage: **TXS12 range:** 2500V ac rms, 2 sec, windings to core.

TXS12AAA: 2500V ac rms, 2sec, winding1/winding2/winding3

TXS12AAC: 1000V dc, 2 sec, winding1/winding2/winding3

Inductance: See tables for TXS12--- range

DC Resistance: See tables for TXS12--- range

Climatic category: 25/105/56

Maximum temperature range: Operating: -25 to +105 °C

 Storage: -55 to 125 °C

Mass:

 Size A: 10g max

Vibration: Frequency sweep of 10Hz to 55Hz with 0.35mm displacement for 6 hours. IEC68-2-6 Test Fc

Requirement: No visible damage, Inductance +/- 10%

Bump: 1000 bumps of each 16ms with acceleration of 98m/s. IEC68-2-29 Test Eb

Requirement: No visible damage, Inductance +/- 10%.

Resistance to soldering heat: Solder bath for 10s @ 260 °C, 6mm from body IEC68-2-20A Method 1B

Solderability: Maximum soldering time, 2.5s @ 260 °C Solder globule test, IEC 68-2-20Ta.

Robustness of terminations:

1Kg (10N) IEC 68-2-21 Test Ua Tensile
500g (5N) IEC 68-2-21 Test Ub Bending

Requirement: No visible damage to the body. No deviation in nominal inductance and dc resistance.

INSPECTION REQUIREMENTS

Visual inspection: Random Sample

Failure Criteria:

- | | |
|---------|--|
| Marking | - Non-legible marking.
- Missing or double marking. |
| Package | - Dimensions out of tolerance.
- Broken or damaged plastic.
- Contamination by oil, flux, etc.
- Voids, holes or cracks. |
| Leads | - Broken, cracked or loose leads.
- More than 10% non-plated surface in the soldering area.
- Blistering, peeling or other surface defects exposing base material.
- Contamination by oil, flux, etc. |
| Packing | - Inconsistent mechanical strength.
- Incorrect labelling and sealing.
- Incorrect quantity and type. |

Inductance: 100%

Limits: +100%, -0%

Insulation Test Voltage: 100%

Limits: As specified, winding/winding.

PRIMEWORLD LIMITED

Derwent, Sawbridgeworth Road, Hatfield Heath, Bishop's Stortford, HERTS, CM22 7DR

Tel: 01279 730031

Fax: 01279 731113

www.primeworld.co.uk

TXS12A-- RANGE:

CODE SIZE...A--	MINIMUM INDUCTANCE (μ H) @ 1KHz	LEAKAGE INDUCTANCE (μ H) typ	DC RESISTANCE (m Ω) MAX	TURNS RATIO N1:N2:N3	MAX ET _{op} V μ sec	FUNCTION
TXS12AAA	380	1	250	20:20:20 (TEX-E)	30	REINFORCED INSULATION GATE DRIVE
TXS12AAB	2400	4	350	50:0:0	75	CURRENT SENSE
TXS12AAC	980	2	250	32:32:32	50	DC/DC GATE DRIVE
TXS12AAD	9600	16	750	100:0:0	150	CURRENT SENSE
TXS12AAE	40000	64	1800	200:0:0	300	CURRENT SENSE
TXS12AAF	2400	6	550	50:0:0 (TEX-E)	75	REINFORCED INSULATION CURRENT SENSE
TXS12AAH	96	1	20	10:0:0	15	CURRENT SENSE

Mechanical Data

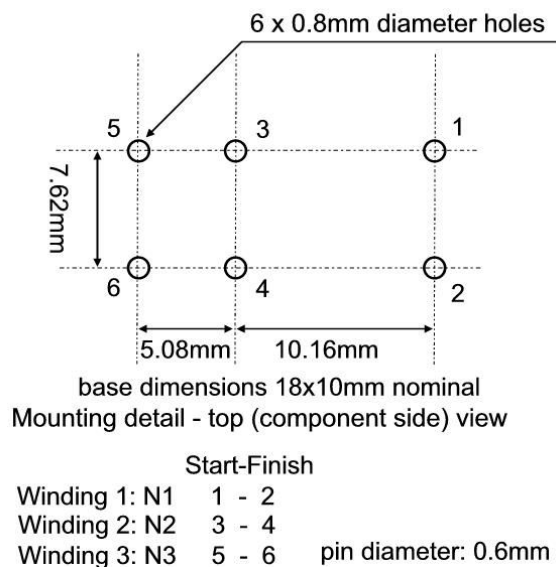
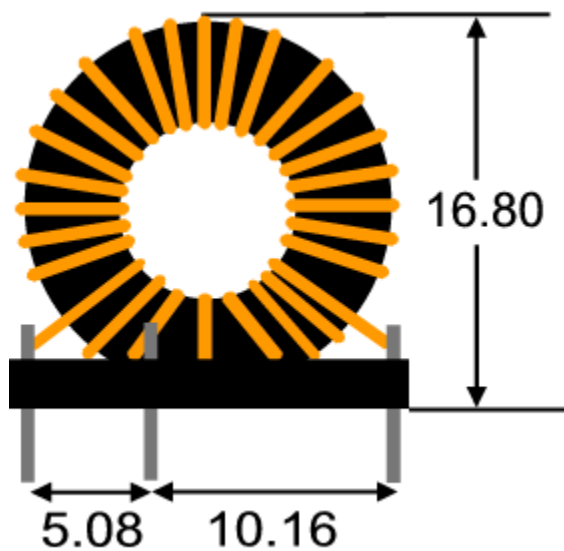

Specifications and information contained in this data sheet are intended for guidance only. The Company's policy is one of continuous improvement and the right to change materials, designs, dimensions and descriptive matter, etc. at any time without notice is reserved.

Primeworld shall not be liable for any loss, direct or consequential, which may result from the use of this information.

© 2009 Primeworld Limited

PRIMEWORLD LIMITED

Derwent, Sawbridgeworth Road, Hatfield Heath, Bishop's Stortford, HERTS, CM22 7DR

Tel: 01279 730031 Fax: 01279 731113 e-mail: sales@primeworld.co.uk