

TXL26 RANGE OF HIGH CURRENT HIGH FREQUENCY SWITCHING REGULATOR INDUCTORS

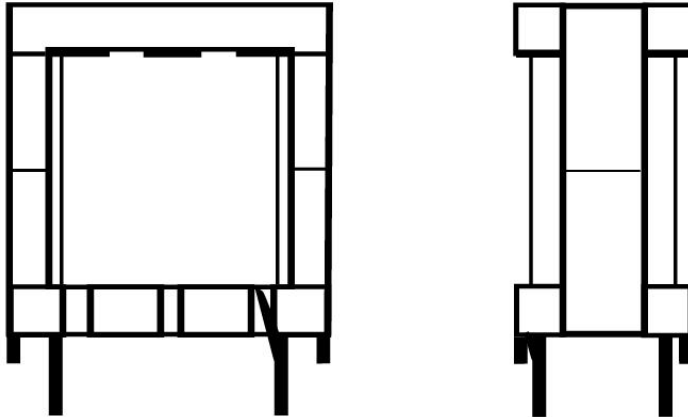

TECHNICAL DESCRIPTION:

Primeworld TXL26--- range of high current inductors is designed to operate in high frequency switching regulator circuits. Windings are "Class 155" (IEC 60317-0-1) or higher temperature enamelled copper wire terminated using SnCu solder on to two of the diagonally opposite tin plated pins of a vertical EF25 bobbin. Bobbin material is Phenolic PM8375 of Sumitomo (Sumidurez) with a flammability rating of UL94 V-0 @ 0.49mm that also withstands assembly process temperatures of up to 260 deg C.

High frequency low loss ferrite cores used in TXL26 series make them a superior choice for high frequency switching regulators. TXL26 range not only offers lower core losses but also low ripple current by keeping inductance virtually constant over the load range. Vertical mounting configuration and its narrow width allow TXL26 range to directly replace toroidal inductors using iron powder and other expensive alloy materials.

The TXL26 range is designed for use in buck regulators, boost regulators, isolated power supplies and dc/dc converters operating up to 500KHz.

RATINGS AND CHARACTERISTICS:

Maximum Working Voltage: 250V ac rms. 400V dc

Rated current: See tables for TXL26--- range

Inductance: See tables for TXL26--- range

DC Resistance: See tables for TXL26--- range

Climatic category: 25/105/56

Maximum temperature range:

Operating: -25 to +105 °C

Storage: -55 to 125 °C

Mass: 34g max

Vibration: Frequency sweep of 10Hz to 55Hz with 0.35mm displacement for 6 hours. IEC68-2-6 Test Fc

Requirement: No visible damage, Inductance +/- 10%

Bump: 1000 bumps of each 16ms with acceleration of 98m/s. IEC68-2-29 Test Eb

Requirement: No visible damage, Inductance +/- 10%.

Resistance to soldering heat: Solder bath for 10s @ 260 °C, 6mm from body IEC68-2-20A Method 1B

Solderability: Maximum soldering time, 2.5s @ 260 °C Solder globule test, IEC 68-2-20Ta.

Robustness of terminations:

1Kg (10N) IEC 68-2-21 Test Ua Tensile

500g (5N) IEC 68-2-21 Test Ub Bending

Requirement: No visible damage to the body. No deviation in nominal inductance and dc resistance.

INSPECTION REQUIREMENTS

Visual inspection: Random Sample

Failure Criteria:

Marking	- Non-legible marking. - Missing or double marking.
Package	- Dimensions out of tolerance. - Broken or damaged plastic. - Contamination by oil, flux, etc. - Voids, holes or cracks.
Leads	- Broken, cracked or loose lead. - More than 10% non-plated surface in the soldering area. - Blistering, peeling or other surface defects exposing base material. - Contamination by oil, flux, etc.
Packing	- Inconsistent mechanical strength. - Incorrect labelling and sealing. - Incorrect quantity and type.

Inductance: 100%

Limits:

+/- 10% for L > 47uH @ 10KHz, 0.1V ac rms.

DC resistance: 100%

Limits: +5% -10%.

Specifications and information contained in this data sheet are intended for guidance only. The Company's policy is one of continuous improvement, and the right to change materials, designs, dimensions and descriptive matter, etc. at any time without notice is reserved. Primeworld shall not be liable for any loss, direct or consequential, which may result from the use of this information. . © 2006 Primeworld Limited

PRIMEWORLD LIMITED

Derwent, Sawbridgeworth Road, Hatfield Heath, Bishop's Stortford, HERTS, CM22 7DR

Tel: 01279 730031

Fax: 01279 731113

e-mail: sales@primeworld.co.uk

TXL26--- RANGE:

	NOMINAL	DC	CONTINUOUS	SATURATING	MAX	Lead Dia.
CODE	INDUCTANCE	RESISITANCE	DC CURRENT	CURRENT (A)	ET _{OP} @ I _{sat}	d
TXL26	L _n (μH) @ 1KHz	(OHM) MAX	(A) @ 50° C	I _{sat} @ 90% L _n	(V.μsec)	(mm) MAX
TXL26AAA	47	0.014	8.55	9.0	70.2	4 pin bobbin
TXL26AAB	68	0.024	6.42	7.6	85.8	4 pin bobbin
TXL26AAC	110	0.030	5.73	5.9	107.6	4 pin bobbin
TXL26AAD	142	0.044	4.77	5.2	123.2	4 pin bobbin
TXL26AAE	180	0.063	3.97	4.6	138.8	4 pin bobbin
TXL26AAF	220	0.069	3.80	4.1	151.3	4 pin bobbin
TXL26AAG	270	0.096	3.23	3.8	169.9	4 pin bobbin
TXL26AAH	300	0.101	3.14	3.6	179.1	4 pin bobbin
TXL26AAI	330	0.106	3.07	3.4	187.9	4 pin bobbin
TXL26AAJ	390	0.147	2.61	3.1	204.3	4 pin bobbin
TXL26AAK	470	0.161	2.49	2.9	224.2	4 pin bobbin

Mechanical Data

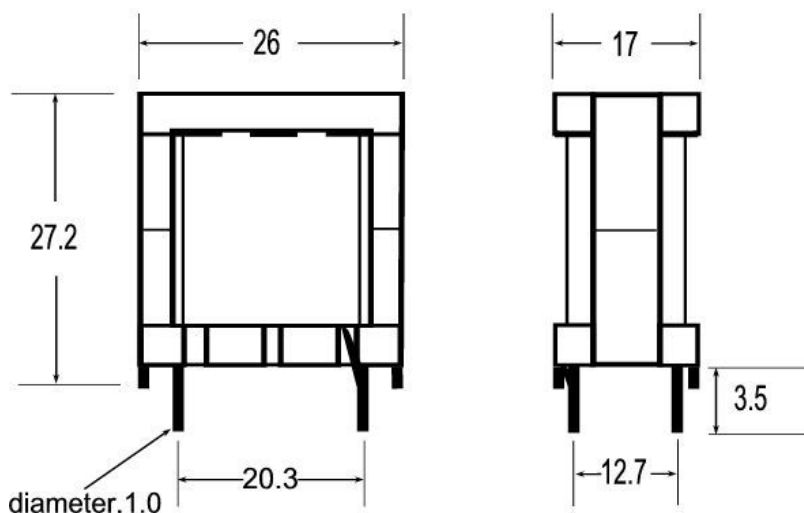

ALL DIMENSIONS ARE IN mm +/-0.5mm

Mounting Detail

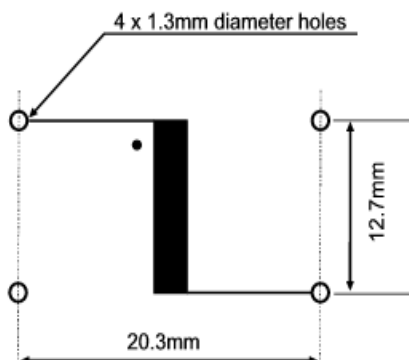

Sixth letter of component code indicates terminal orientation

Mounting detail:

Top (component side) view – Letter A
Bottom (solder side) view – Letter B

Specifications and information contained in this data sheet are intended for guidance only. The Company's policy is one of continuous improvement, and the right to change materials, designs, dimensions and descriptive matter, etc. at any time without notice is reserved. Primeworld shall not be liable for any loss, direct or consequential, which may result from the use of this information. . © 2006 Primeworld Limited

PRIMEWORLD LIMITED

Derwent, Sawbridgeworth Road, Hatfield Heath, Bishop's Stortford, HERTS, CM22 7DR

Tel: 01279 730031

Fax: 01279 731113

e-mail: sales@primeworld.co.uk