

TXL04A RANGE OF COMMON MODE TOROIDAL INDUCTORS



TECHNICAL DESCRIPTION:

Primeworld TXL04A range of common mode toroidal inductors is manufactured in one mechanical outline (A), providing a range of inductance values at different current levels for common mode noise suppression applications.

Windings are enamelled copper wire, wound on a 25mm diameter, high permeability ferrite toroidal core. Wound core is secured on to a flame retardant glass reinforced PET (*Rynite FR530*) base with a non-releasable tie. The base has an industrial standard foot-print, with four asymmetric tin plated terminal pins to which the windings are terminated using SnCu solder. Also, at the top of the assembly, the two windings are separated by a non-releasable tie.

The TXL04A range is designed for use in power supplies, dc/dc converters and inverters, EMI/RFI noise suppression, and is particularly suitable for mains input filter applications.

RATINGS AND CHARACTERISTICS:

Maximum Working Voltage: 275V ac rms., 500V dc

Insulation Test Voltage: 2500V ac rms, 2sec, winding1/winding2

Rated current: See tables for TXL04--- range

Inductance: See tables for TXL04--- range

DC Resistance: See tables for TXL04--- range

Climatic category: 25/105/56

Maximum temperature range: Operating: -25 to +105 °C

Storage: -55 to 125 °C

Mass:

Size A: 25g max

Vibration: Frequency sweep of 10Hz to 55Hz with 0.35mm displacement for 6 hours. IEC68-2-6 Test Fc

Requirement: No visible damage, Inductance +/- 10%

Bump: 1000 bumps of each 16ms with acceleration of 98m/s. IEC68-2-29 Test Eb

Requirement: No visible damage, Inductance +/- 10%.

Resistance to soldering heat: Solder bath for 10s @ 260 °C, 6mm from body IEC68-2-20A Method 1B

Solderability: Maximum soldering time, 2.5s @ 260 °C Solder globule test, IEC 68-2-20Ta.

Robustness of terminations:

1Kg (10N) IEC 68-2-21 Test Ua Tensile
500g (5N) IEC 68-2-21 Test Ub Bending

Requirement: No visible damage to the body. No deviation in nominal inductance and dc resistance.

INSPECTION REQUIREMENTS

Visual inspection: Random Sample

Failure Criteria:

- | | |
|---------|--|
| Marking | - Non-legible marking.
- Missing or double marking. |
| Package | - Dimensions out of tolerance.
- Broken or damaged plastic.
- Contamination by oil, flux, etc.
- Voids, holes or cracks. |
| Leads | - Broken, cracked or loose leads.
- More than 10% non-plated surface in the soldering area.
- Blistering, peeling or other surface defects exposing base material.
- Contamination by oil, flux, etc. |
| Packing | - Inconsistent mechanical strength.
- Incorrect labelling and sealing.
- Incorrect quantity and type. |

Inductance: 100% **Limits:** +80%, -25%

DC resistance: 100% **Limits:** +5% -10%.

Insulation Test Voltage: 100% **Limits:** > 4000V DC

Specifications and information contained in this data sheet are intended for guidance only. The Company's policy is one of continuous improvement and the right to change materials, designs, dimensions and descriptive matter, etc. at any time without notice is reserved. Primeworld shall not be liable for any loss, direct or consequential, which may result from the use of this information. © 2007 Primeworld Limited

PRIMEWORLD LIMITED

Derwent, Sawbridgeworth Road, Hatfield Heath, Bishop's Stortford, HERTS, CM22 7DR

Tel: 01279 730031 Fax: 01279 731113 sales@primeworld.co.uk www.primeworld.co.uk

TXL04-- RANGE:

	NOMINAL	LEAKAGE	DC	DC
CODE	INDUCTANCE	INDUCTANCE	RESISTANCE	CURRENT (A)
SIZE...A--	(mH) @ 1KHz	(uH) typ	(mΩ) MAX	@ 70 ° C
TXL04AAA	18.0	150	660	1
TXL04AAB	7.5	58	165	2
TXL04AAC	3.2	28	72	3
TXL04AAD	2.4	20	41	4
TXL04AAE	1.4	12	20	6
TXL04AAF	0.75	8	10	8
TXL04ABC	3.2	26	52	3.6
TXL04ABH	0.33	4	3.6	14
TXL04ABE	1.4*	10	10	8
TXL04ACC**	3.2	20	22	6
TXL04ABB**	9.6	58	165	2

* Inductance +60% -40% **Provisional data

Mechanical Data

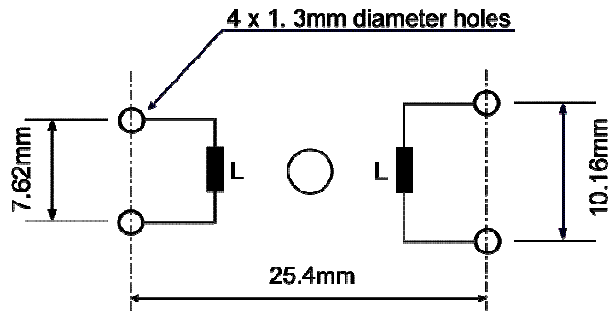

Mounting detail - top (component side) view

SIZE	H	W	D
A	32	31	16

Pin dimensions: 1.2mm x 0.4mm Pin length below base: 5mm TOLERANCES +/- 10%

Specifications and information contained in this data sheet are intended for guidance only. The Company's policy is one of continuous improvement and the right to change materials, designs, dimensions and descriptive matter, etc. at any time without notice is reserved. Primeworld shall not be liable for any loss, direct or consequential, which may result from the use of this information. © 2007 Primeworld Limited

PRIMEWORLD LIMITED

Derwent, Sawbridgeworth Road, Hatfield Heath, Bishop's Stortford, HERTS, CM22 7DR

Tel: 01279 730031 Fax: 01279 731113 sales@primeworld.co.uk www.primeworld.co.uk